

DESCRIPTION

1 Guide units series "WUG" for cylinders to ISO 6432 standard act as devices against rotation of the piston rod in the presence of torques and they are used to carry out multi-axis systems where high movement precision is required. Guide units are available in single and double version with mechanical stop as standard, or housing for decelerator, and are supplied with self-lubricating bushings (for low speeds or heavy loads) and for size 20-25 with recirculating ball bearing sleeves for high speeds.

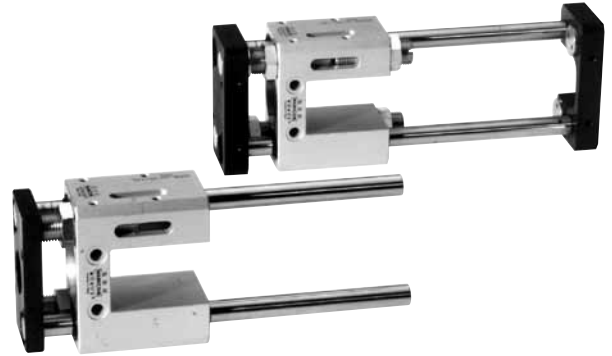

TECHNICAL DATA

Working temperature	0 ÷ +80 °C
Size	12 - 16, 20 - 25
Standard strokes (mm)	50, 100, 150, 200, 250, 300, 350, 400, 450, 500
Versions	Single unit Double unit

MATERIALS

Body	Anodized aluminium alloy
Self-aligning radial joint	Steel
Adjustable mechanical stop as standard	Brass
End flanges	Single unit: galvanized steel Double unit: anodized aluminium alloy
Guide bars	C45 chromium-plated steel (sliding type on bushings) Hardened steel (sliding type with sleeves)
Bushings	Self-lubricating sintered bronze with wiper ring
Sleeves	Recirculating ball bearings with wiper ring
Clamp	Brass
Scrapers ring	NBR rubber

ORDER KEY

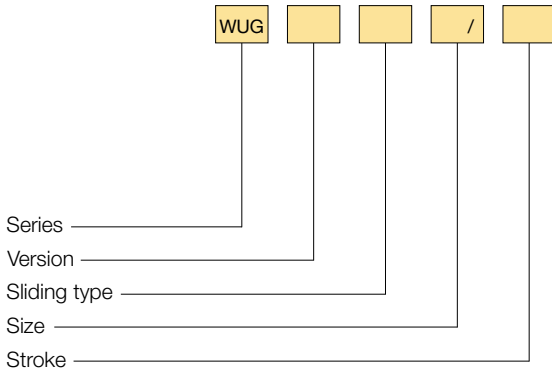

VERSION

Single unit D Double unit

SLIDING TYPE

B On bushings M With sleeves*

* Supplied only with size 20 - 25

ORDER EXAMPLES

Single guide unit, size 20 - 25, 150 mm stroke, with sleeves + cylinder series "U" Ø 25, 150 mm stroke, double acting, magnetic piston type, ASSEMBLED:

WUGM 20 - 25/150 + 25/150 UDE + M/WUG

Single guide unit, size 12 - 16, 100 mm stroke, on bushings:

WUGB 12 - 16/100

Double guide unit, size 20 - 25, 100 mm stroke, with sleeves:

WUGDM 20 - 25/100

ASSEMBLY

WUG + cylinders series U (Ø 16 ÷ 25)

M/WUG

TECHNICAL INFORMATION

WUG SINGLE GUIDE UNIT

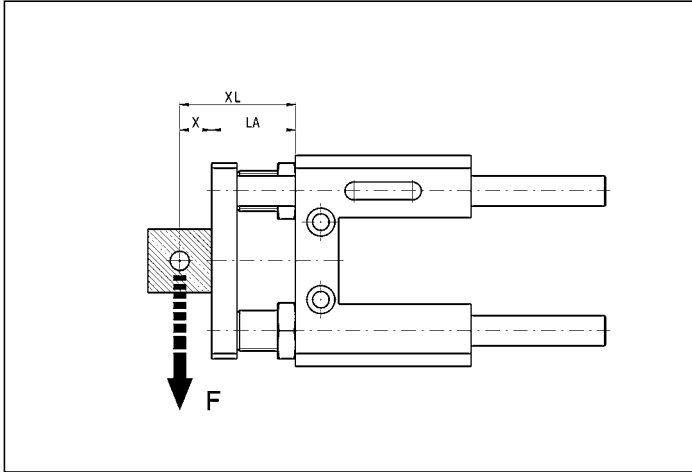

WUGD DOUBLE GUIDE UNIT

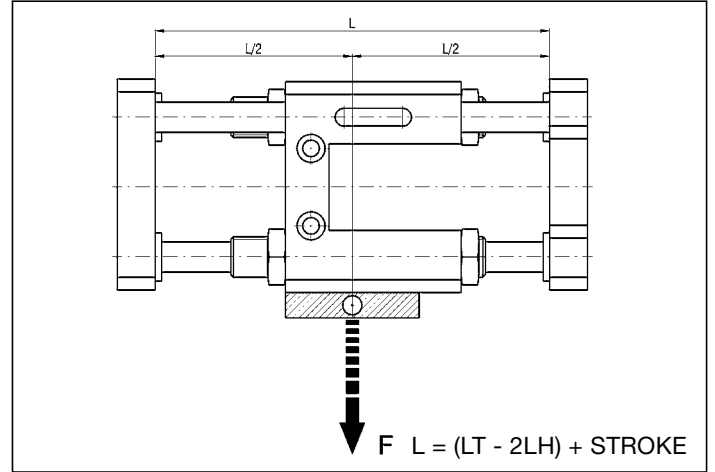

MAXIMUM PERMISSIBLE LOAD-WUG VERSION B

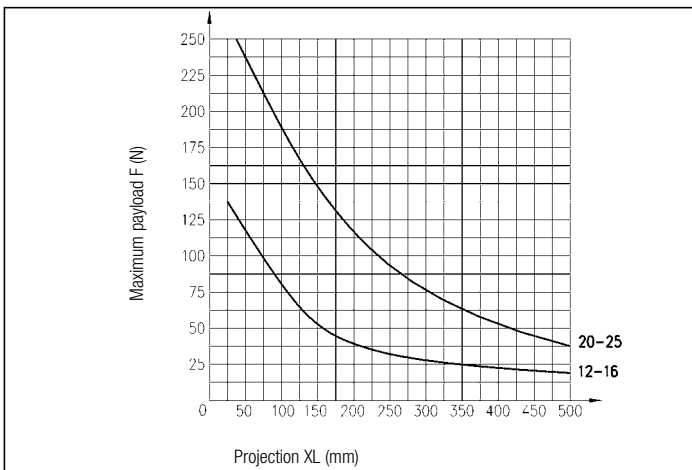

MAXIMUM PERMISSIBLE LOAD-WUGD VERSION B

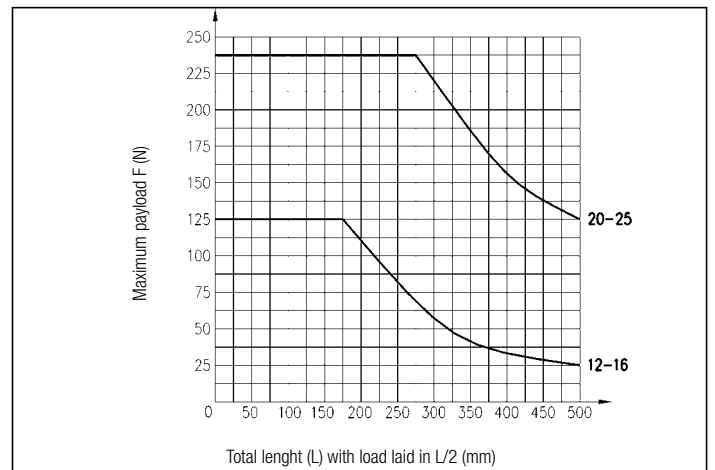

MAXIMUM PERMISSIBLE LOAD-WUG VERSION M

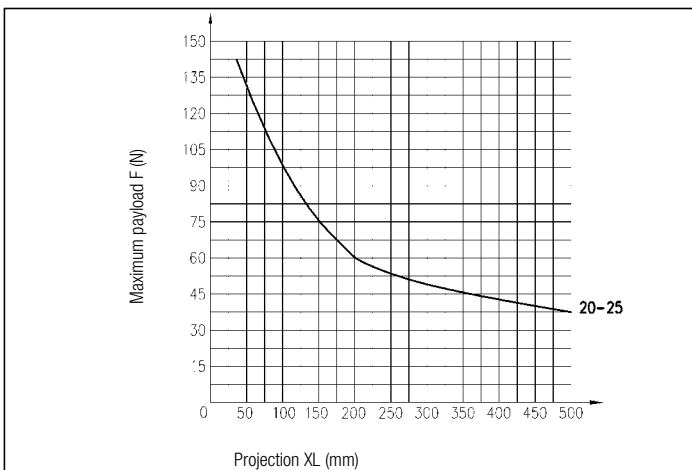

MAXIMUM PERMISSIBLE LOAD-WUGD VERSION M

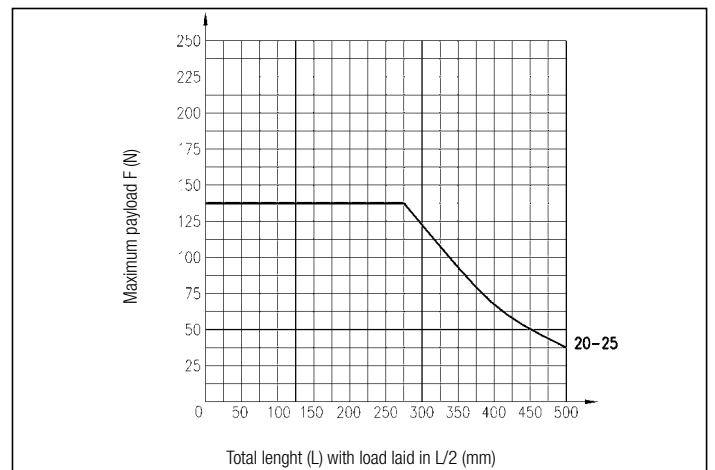

WUG SINGLE GUIDE UNIT

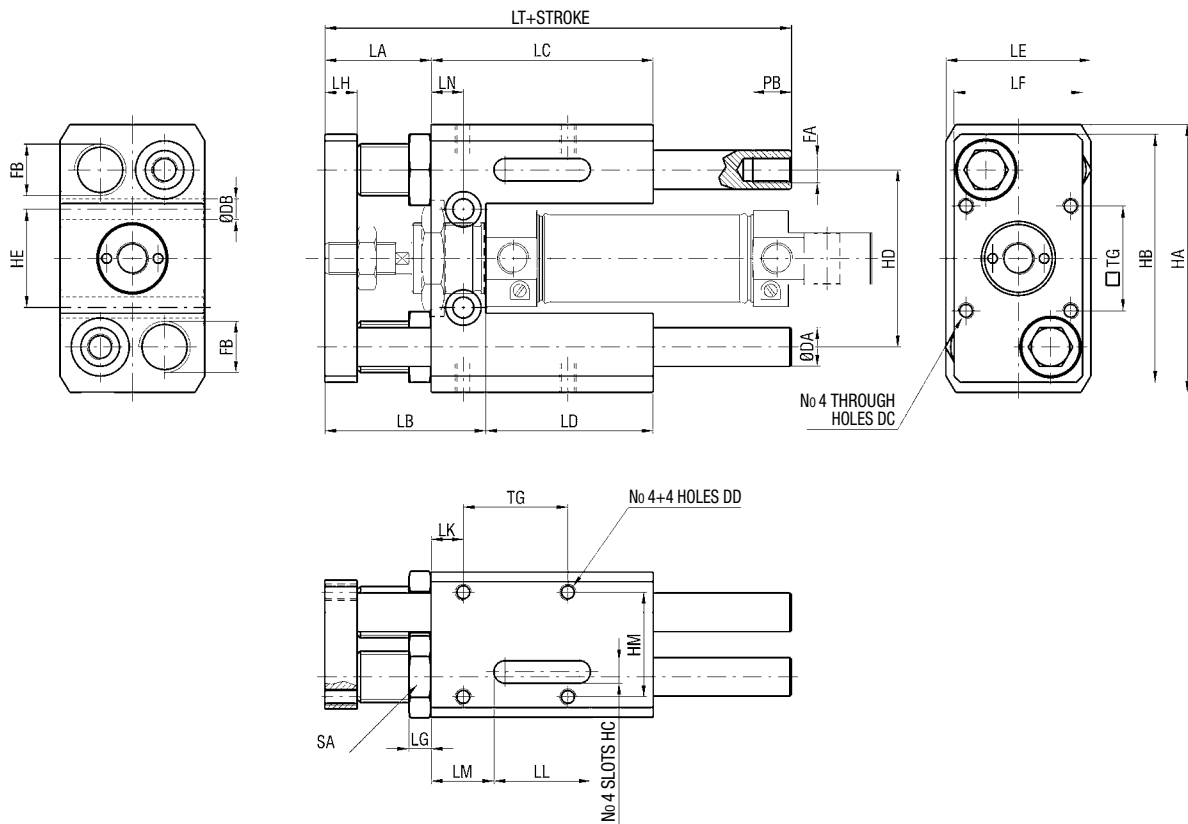

DIMENSIONS AND WEIGHTS

SIZE	DA	DB	DC	DD	FA		FB	HA	HB	HC	HD	HE	HM	LA	LB	LC	LD	LE	LF	LG	LH
12-16	10	5,2	M4	M5	M6		M12x1,25	65	60	6	47	24	32,5	25	38	60	47	40	35	7	10
20	B12 M10	6,5	M4	M5	BM8 MM6		M16x1,5	83	77	7	55	30,5	32,5	27	44	69	52	45	40	7	10
25	B12 M10	6,5	M4	M5	BM8 MM6		M16x1,5	83	77	7	55	30,5	32,5	32	50	69	52	45	40	7	10

SIZE	LK	LL	LM	LN	LT	PB	SA	TG	WEIGHT (g)		INCREM. (g) every 10 mm	
12-16	19	16	22	6,5	100	12	Ch.14	22	690		12	
20	10	30	19,5	10	115	12	Ch.21	32,5	B890 M830	B17 M12		
25	10	30	19,5	10	115	12	Ch.21	32,5	B890 M830	B17 M12		

B - Bushings

M - Sleeves

WUGD DOUBLE GUIDE UNIT

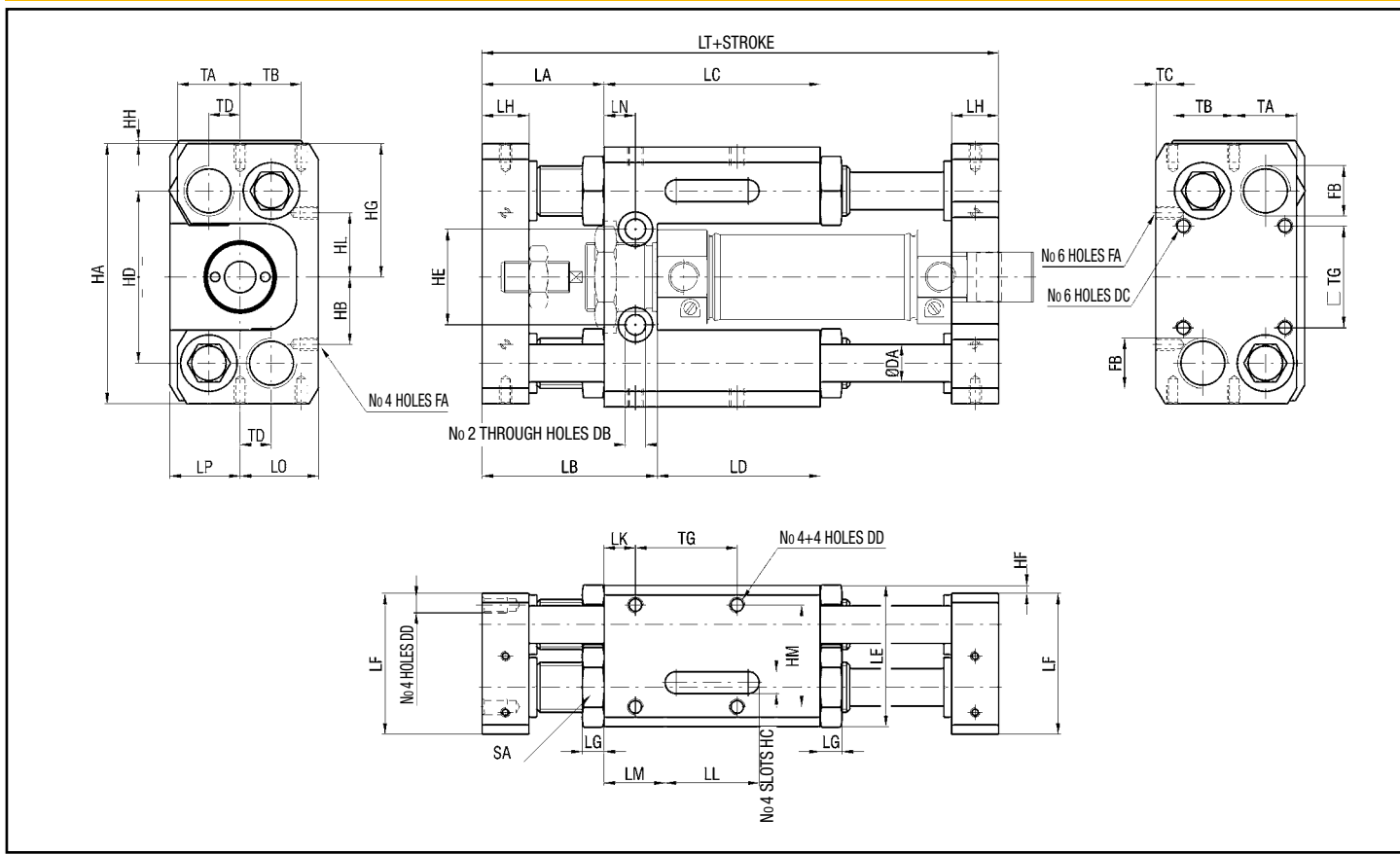

DIMENSIONS AND WEIGHTS

SIZE	DA	DB	DC	DD	FA	FB	HA	HB	HC	HD	HE	HF	HG	HH	HL	HM	LA	LB	LC	LD	LE
12-16	10	5,2	M4	M5	M4	M12x1,25	65	18	6	47	24	1,3	30,5	1	18	32,5	30	43	60	47	40
20	B12 M10	6,5	M4	M5	M4	M16x1,5	83	21,5	7	55	30,5	2,5	40,5	1	20,5	32,5	33	50	69	52	45
25	B12 M10	6,5	M4	M5	M4	M16x1,5	83	21,5	7	55	30,5	2,5	40,5	1	20,5	32,5	39	56	69	52	45

SIZE	LF	LG	LH	LK	LL	LM	LN	LO	LP	LT	SA	TA	TB	TC	TD	TG	WEIGHT (g)	INCREM. (g) every 10 mm
12-16	40	7	15	19	16	22	6,5	22,5	19	120	Ch.14	17,5	17,5	5	8,5	22	740	12
20	45	7	15	10	30	19,5	10	25	22,15	135	Ch.21	20	19,5	5,5	10	32,5	B1170 M1110	B18 M12
25	45	7	15	10	30	19,5	10	25	22,15	135	Ch.21	20	19,5	5,5	10	32,5	B1170 M1110	B18 M12

B - Bushings
M - Sleeves

CLAMP FOR DECELERATOR WUGCD SIZE

SIZE	FA	FB	L	WEIGHT (g)
12-16	M12x1,5	M8x1	35	20
20-25	M16x1,5	M8x1	40	50

CLAMP FOR MAGNETIC PROXIMITY WUGCP SIZE

SIZE	FA	FB	L	WEIGHT (g)
12-16	M12x1,5	M8x1	25	12
20-25	M16x1,5	M8x1	25	31

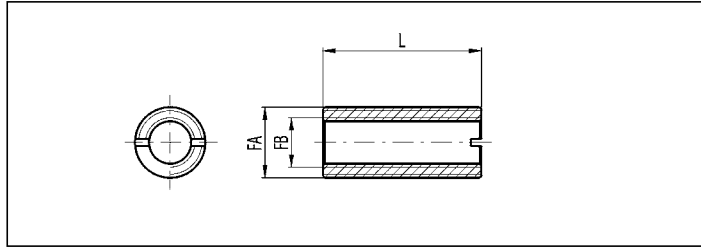

Accessories

WUG - Guide unit for cylinders to ISO 15552 standard Ø 32 ÷ 63

DESCRIPTION

Guide unit series "WUG" for cylinders to ISO 15552 standard (serie X e XT) act as devices against rotation of the piston rod in the presence of torques and they are used to carry out multi-axis systems where high movement precision is required. Guide units are available in single and double version, and are supplied with self-lubricating bushings (for low speeds or heavy loads), or with recirculating ball bearing sleeves (for high speeds).

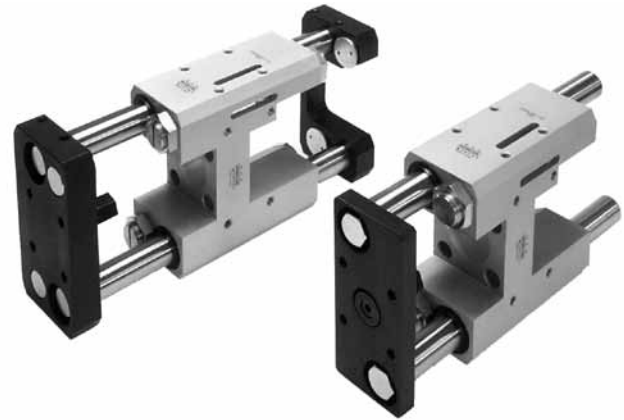

1

TECHNICAL DATA

Working temperature	0 ÷ +80 °C
Size	32, 40, 50, 63
Standard strokes (mm)	25, 50, 100, 150, 200, 250, 300, 350, 400, 500
Versions	Single unit Double unit

MATERIALS

Body	Anodized aluminium alloy
Self-aligning radial joint	Steel
Adjustable mechanical stop as standard	Brass
End flanges	Single unit: galvanized steel Double unit: anodized aluminium alloy
Guide bars	C45 chromium-plated steel (sliding type on bushings); Hardened steel (sliding type with sleeves)
Bushings	Self-lubricating sintered bronze with wiper ring
Sleeves	Recirculating ball bearings with wiper ring
Clamp	Brass
Scrapers	NBR rubber

ORDER KEY

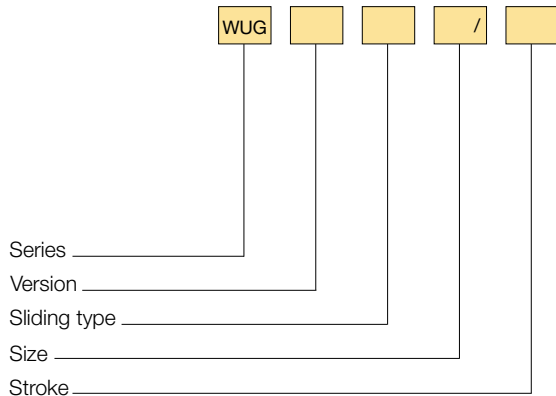

VERSION

Single unit _____ D Double unit

SLIDING TYPE

B On bushings _____ M With sleeves

ORDER EXAMPLES

Single guide unit, size 63, 150 mm stroke, with sleeves + cylinder series "X" Ø 63, double acting, 150 mm stroke, magnetic piston type, ASSEMBLED:
WUGM 63/150 + 63/150 X/M + M/WUG

Single guide unit, size 40, 250 mm stroke, with sleeves:
WUGM 40/250

Double guide unit, size 50, 100 mm stroke, with bushings:
WUGDB 50/100

ASSEMBLY

"WUG" + cylinders series "X" or "XT" **M/WUG**

TECHNICAL INFORMATION

1

WUG SINGLE GUIDE UNIT

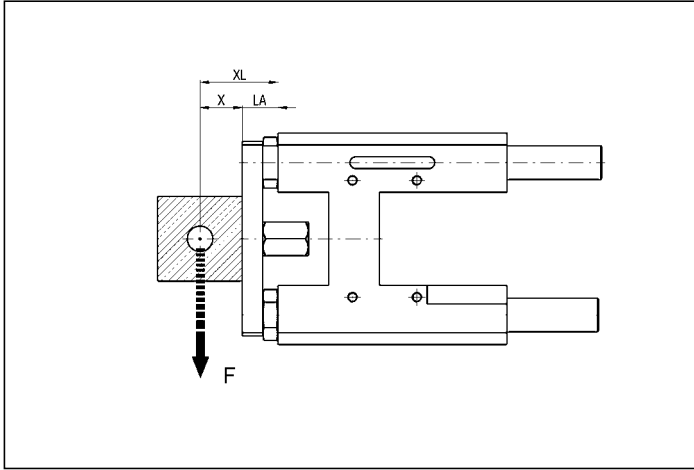

WUGD DOUBLE GUIDE UNIT

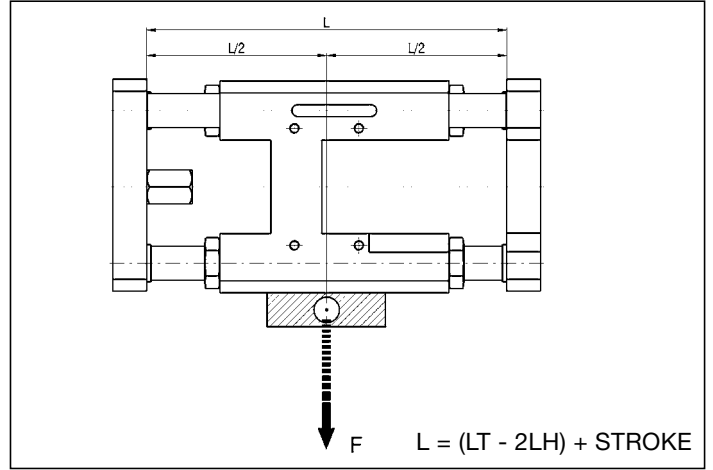

MAXIMUM PERMISSIBLE LOAD-WUG VERSION B

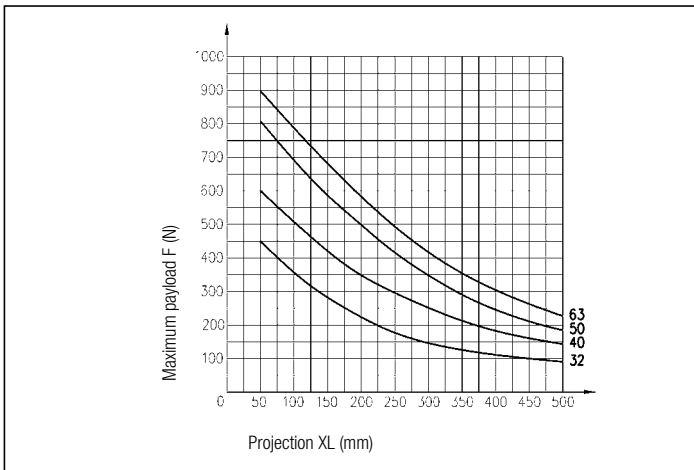

MAXIMUM PERMISSIBLE LOAD-WUGD VERSION B

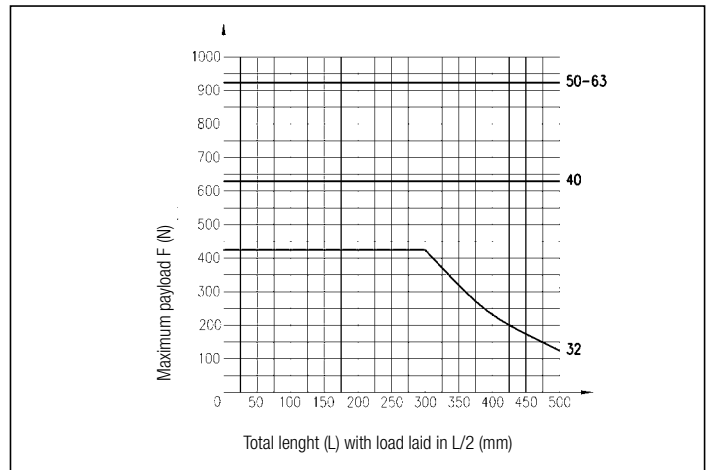

MAXIMUM PERMISSIBLE LOAD-WUG VERSION M

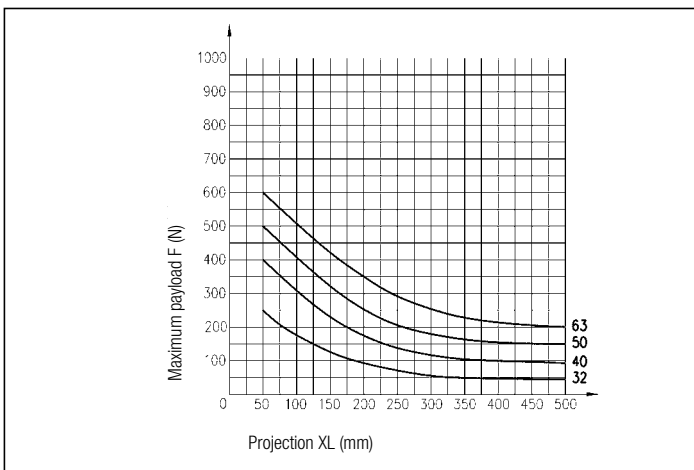

MAXIMUM PERMISSIBLE LOAD-WUGD VERSION M

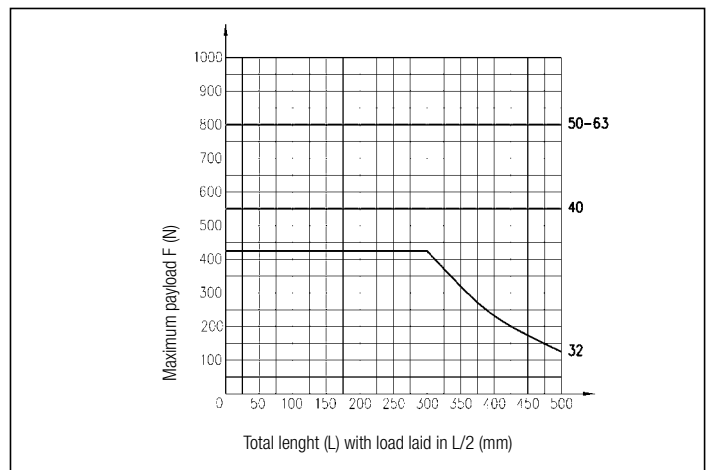

Accessories

WUG - Guide unit for cylinders to ISO 15552 standard Ø 32 ÷ 63

WUG SINGLE GUIDE UNIT

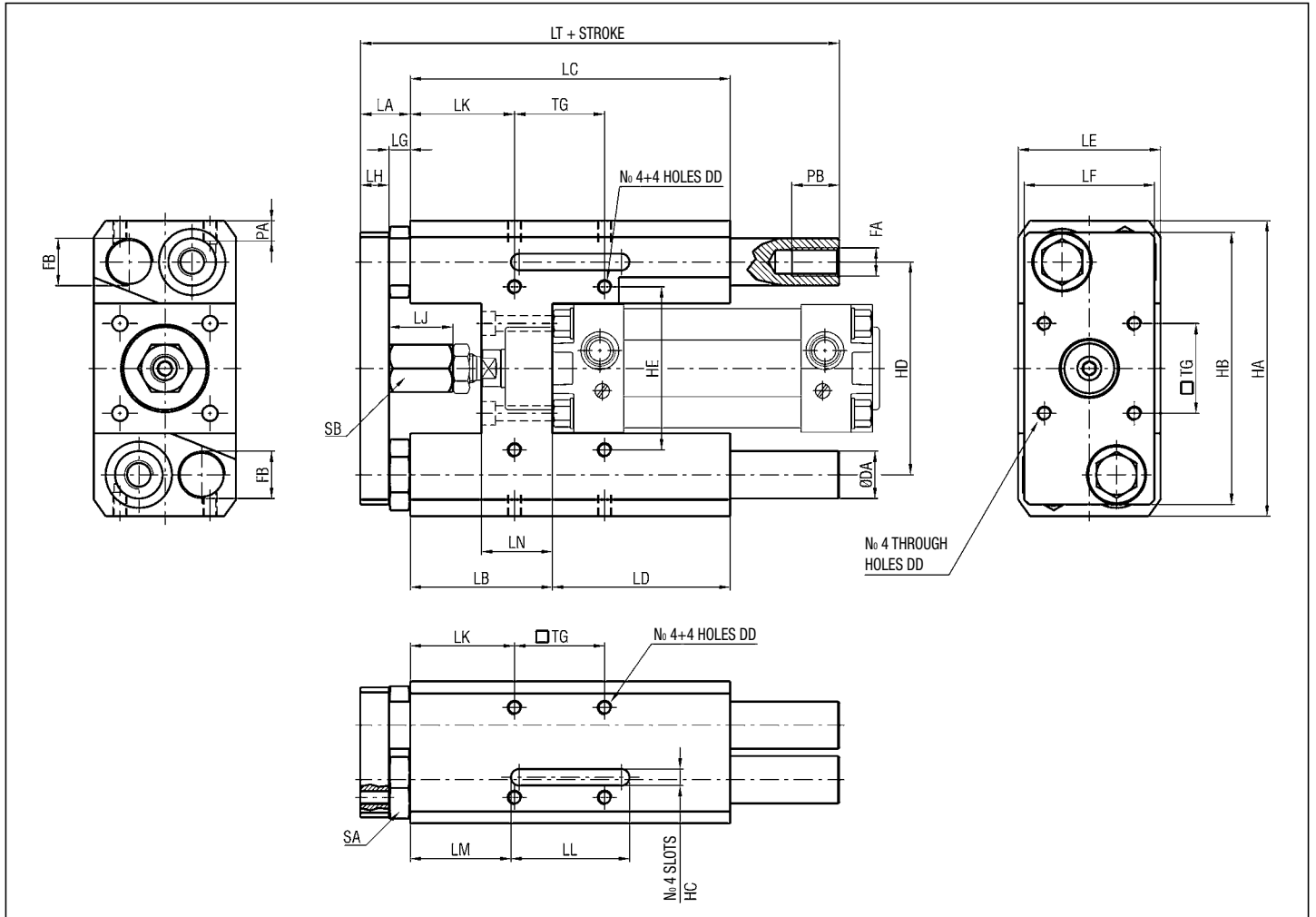

DIMENSIONS AND WEIGHTS

SIZE	DA	DD	FA	FB	HA	HB	HC	HD	HE	LA	LB	LC	LD	LE	LF	LG	LH
32	16	M6	M10x1,25	M18x1,5	112	100	7	79	61	20	50	120	70	50	45	8	12
40	20	M6	M12x1,25	M20x1,5	125	115	7	90	69	21	60	135	75	60	55	9	12
50	25	M8	M16x1,5	M24x2	150	144	7	108	85	25	70	150	80	70	65	10	15
63	25	M8	M16x1,5	M27x2	162	155	7	119	100	27	73	180	107	80	75	12	15

SIZE	LJ	LK	LL	LM	LN	LT	PA	PB	SA	SB	TG	WEIGHT WUGB (g)	INCREM. (g) every 10 mm	WEIGHT WUGM (g)	INCREM. (g) every 10 mm
32	22	38	50	34,5	25	157	6	15	Ch.23	Ch.17	32,5	2060	29	1815	31
40	27	44	50	42,5	30	172	8	20	Ch.26	Ch.20	38	2905	45	2760	50
50	32	47	50	50	35	190	8	25	Ch.30	Ch.20	46,5	4780	65	4525	76
63	32	49,5	50	65	35	225	9,5	25	Ch.36	Ch.20	56,5	6315	65	5950	87

CLAMP FOR DECELERATOR - WUGCD SIZE

SIZE	FA	FB	L	WEIGHT (g)
32	M18x1,5	M12x1	40	50
40	M20x1,5	M14x1,5	45	60
50	M24x2	M16x1,5	50	105
63	M27x2	M20x1,5	60	130

CLAMP FOR MAGNETIC PROXIMITY SWITCH - WUGCP SIZE

SIZE	FA	FB	L	WEIGHT (g)
32	M18x1,5	M12x1	40	47
40	M20x1,5	M12x1	40	67
50	M24x2	M12x1	45	128
63	M27x2	M12x1	45	173

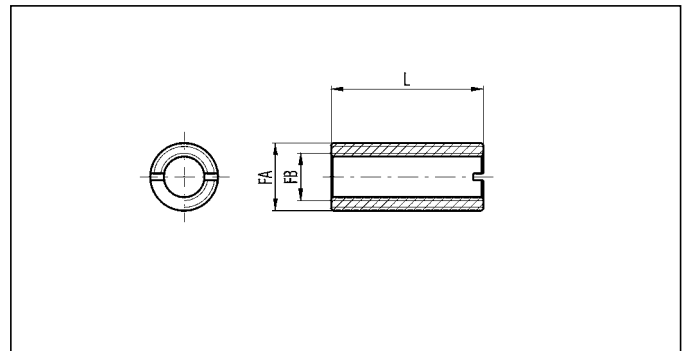

Accessories
WUG - Guide unit for cylinders
to ISO 15552 standard Ø 32 ÷ 63

WUGD DOUBLE GUIDE UNIT

1

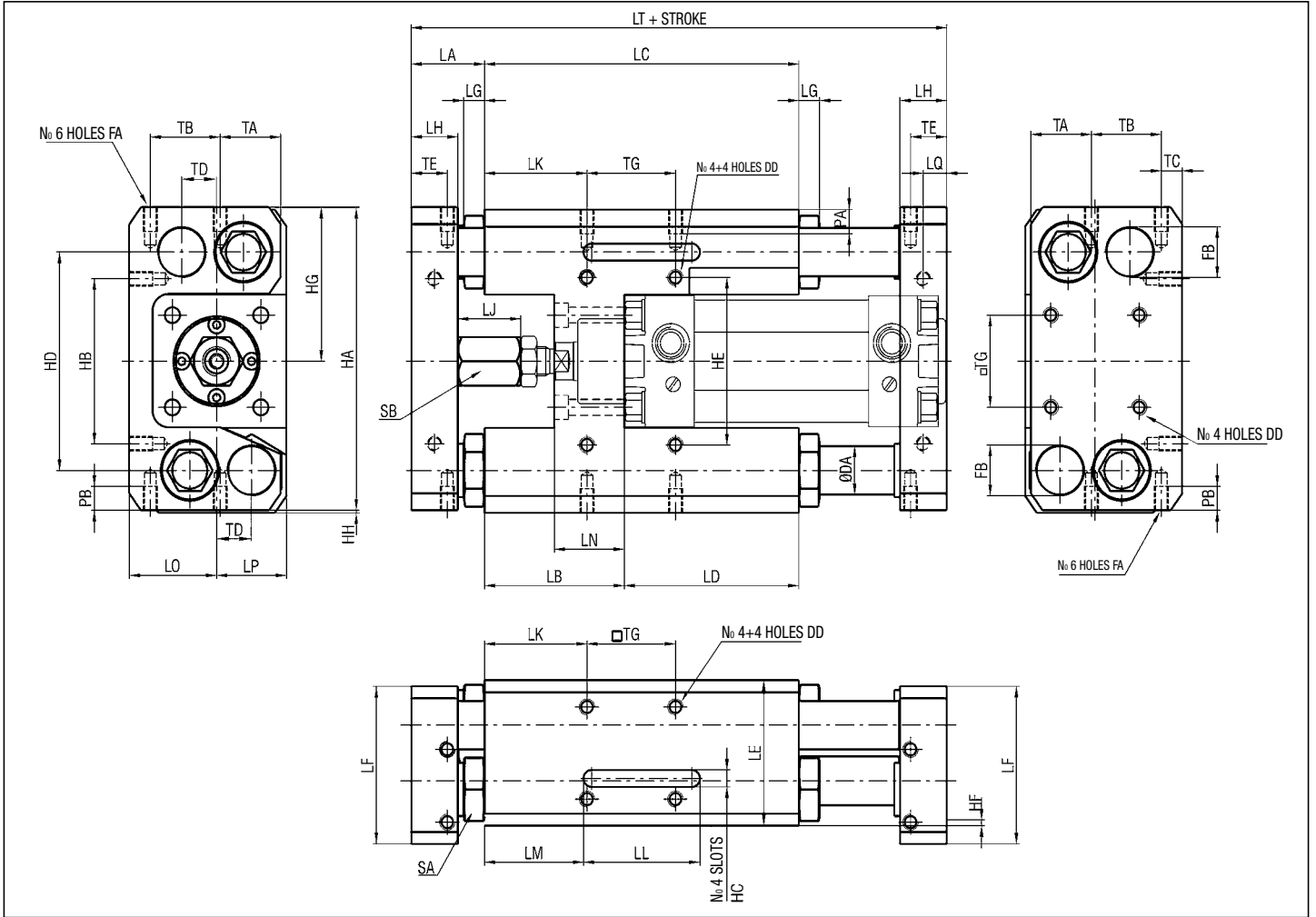

DIMENSIONS AND WEIGHTS

SIZE	DA	DD	FA	FB	HA	HB	HC	HD	HE	HF	HG	HH	LA	LB	LC	LD	LE
32	16	M6	M5	M18x1,5	112	60	7	79	61	1	57	1	28,5	50	120	70	50
40	20	M6	M6	M20x1,5	125	68	7	90	69	2,5	63,5	1	31,5	60	135	75	60
50	25	M8	M8	M24x2	150	79	7	108	85	1	76	1	37,5	70	150	80	70
63	25	M8	M8	M27x2	162	89	7	119	100	1	82	1	39,5	73	180	107	80

SIZE	LF	LG	LH	LJ	LK	LL	LM	LN	LO	LP	LQ	LT	PA	PB	SA	SB	TA
32	58	8	18	22	38	50	34,5	25	34	25	9	181	6	10	Ch.23	Ch.17	24
40	65	9	20	27	44	50	42,5	30	37,5	30	10	200	8	10	Ch.26	Ch.20	26
50	78,5	10	25	32	47	50	50	35	44,5	35	12,5	225	8	12	Ch.30	Ch.20	33,5
63	93	12	25	32	49,5	50	65	35	54	40	12,5	260	9,5	12	Ch.36	Ch.20	40

SIZE	TB	TC	TD	TE	TG	WEIGHT WUGDB (g)	INCREM. (g) every 10 mm	WEIGHT WUGDM (g)	INCREM. (g) every 10 mm
32	24,5	9,5	9,5	14	32,5	2320	29	2250	31
40	30	9	11,5	15,5	38	3480	45	3340	50
50	33	12	13	19	46,5	5750	65	5480	76
63	41	12	17	19	56,5	6445	65	6065	87